

# CAL-A, BIMETAL LUG

**Application:**

Used for transition connection of aluminium cable or aluminium alloy cable with copper end of electrical equipment in low voltage.

**Material:** Al ≥ 99.5%, Cu ≥ 99.9%

**Feature:**

- Oil blocking structure
- Friction welded
- Prefilled with jointing compound.

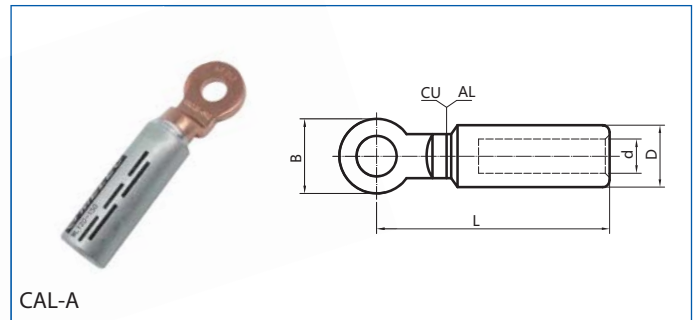

Type	Conductor Size (mm <sup>2</sup> )	Dimensions				Stud Size	Pack(pcs)
		L(mm)	d(mm)	D(mm)	B(mm)		
CAL-16A-8	16	67.5	5.8	16	20	M8	70x8
CAL-16A-10		67.5	5.8	16	20	M10	
CAL-16A-12		67.5	5.8	16	20	M12	
CAL-25A-8	25	67.5	6.7	16	20	M8	70x8
CAL-25A-10		67.5	6.7	16	20	M10	
CAL-25A-12		67.5	6.7	16	20	M12	
CAL-35A-8	35	67.5	8.2	16	20	M8	70x8
CAL-35A-10		67.5	8.2	16	20	M10	
CAL-35A-12		67.5	8.2	16	20	M12	
CAL-50A-8	50	75	9.2	20	24	M8	40x8
CAL-50A-10		75	9.2	20	24	M10	
CAL-50A-12		75	9.2	20	24	M12	
CAL-70A-8	70	75	11.2	20	24	M8	40x8
CAL-70A-10		75	11.2	20	24	M10	
CAL-70A-12		75	11.2	20	24	M12	
CAL-70A-14		75	11.2	20	24	M14	
CAL-95A-10	95	75	12.7	20	24	M10	40x8
CAL-95A-12		75	12.7	20	24	M12	
CAL-95A-14		75	12.7	20	24	M14	
CAL-120A-10	120	98	13.9	25	30	M10	40x4
CAL-120A-12		98	13.9	25	30	M12	
CAL-120A-14		98	13.9	25	30	M14	
CAL-150A-10	150	98	15.7	25	30	M10	40x4
CAL-150A-12		98	15.7	25	30	M12	
CAL-150A-14		98	15.7	25	30	M14	
CAL-150A-16		98	15.7	25	30	M16	

Type	Conductor Size (mm <sup>2</sup> )	Dimensions				Stud Size	Pack(pcs)
		L(mm)	d(mm)	D(mm)	B(mm)		
CAL-185A-10	185	104	17.5	32	35	M10	25x4
CAL-185A-12		104	17.5	32	35	M12	
CAL-185A-14		104	17.5	32	35	M14	
CAL-185A-16		104	17.5	32	35	M16	
CAL-240A-10	240	104	19.7	32	35	M10	25x4
CAL-240A-12		104	19.7	32	35	M12	
CAL-240A-14		104	19.7	32	35	M14	
CAL-240A-16		104	19.7	32	35	M16	
CAL-300A-10	300	112	23.5	34	36	M10	20x4
CAL-300A-12		112	23.5	34	36	M12	
CAL-300A-14		112	23.5	34	36	M14	
CAL-300A-16		112	23.5	34	36	M16	
CAL-400A-10	400	112	26.5	40	36	M10	16x4
CAL-400A-12		112	26.5	40	36	M12	
CAL-400A-14		112	26.5	40	36	M14	
CAL-400A-16		112	26.5	40	36	M16	
CAL-500A-10	500	148	29	41	36	M10	12x4
CAL-500A-12		148	29	41	36	M12	
CAL-500A-16		148	29	41	36	M16	
CAL-500A-20		148	29	41	36	M20	
CAL-630A-16	630	157.5	32.5	47	45	M16	6x4
CAL-630A-20		157.5	32.5	47	45	M20	